

The ultrasonic vibration micro nozzle consists a piezoelectric ceramic and a metal foil, on which over thousands micro nozzles formed. Using the same principle as inkjet printer, this transducer atomizes water or liquids through a matrix of micro holes of around 7-10  $\mu\text{m}$ .

The micro nozzles ultrasonic atomizing transducer can use siphon to draw small amount liquids to the surface of metal foil and then to atomize, which is much efficiency than the conventional ultrasonic atomizer for which a liquid tank with high level liquid has to be always loaded on the surface of ultrasonic transducers.

**Features**

- Fine and consistent misted particle size
- Adjustable misted particle size
- No loaded liquids require as comparing with conventional atomizers
- High atomizing efficiency
- Less power consumption
- High stability and durability

**Applications**

- Humidification in refrigerated food displays and storage, living environments, and air conditioning plants.
- Inhalation and disinfecting equipment
- Humidification in industrial process control for lubrication, coating and etc.
- Liquids dispensing systems

**Specification:**

Resonant Frequency	143 $\pm$ 5	KHz	
Impedance	10	ohm	typ
Capacitance	2300 $\pm$ 20%	pF	@1KHz , 20°C
Dimensions	L	29.1 $\pm$ 0.2	mm
	W	17.3 $\pm$ 0.1	mm
	T	1.0 $\pm$ 0.1	mm
Metal Material	50	$\mu\text{m}$	PZT Element Ni-Co Alloy
Nozzle size	7 $\pm$ 3	$\mu\text{m}$	

**Impedance/Phase Angle:**

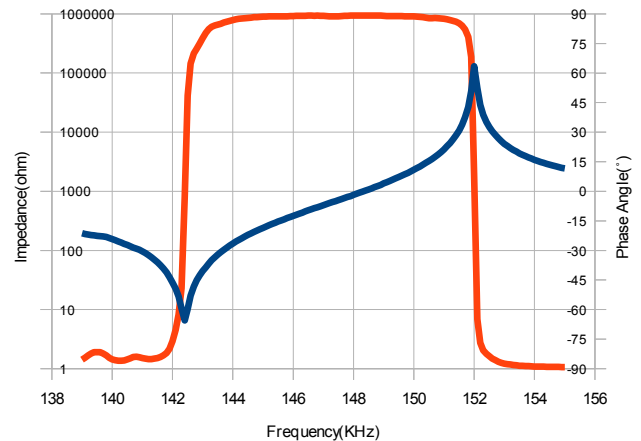

**Construction**

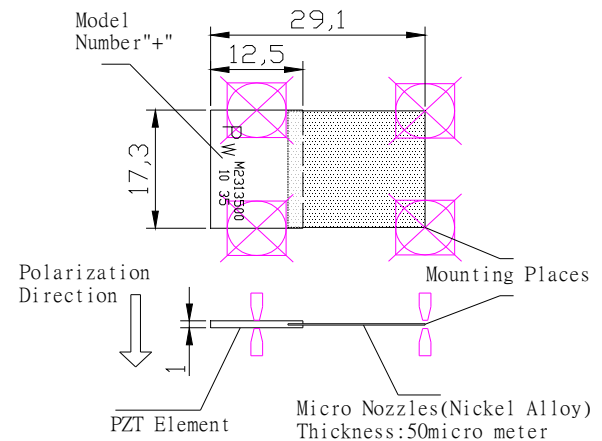

**Driving Circuit**

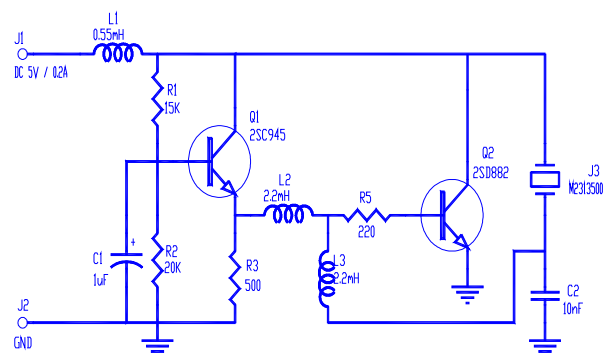

Remark: The negative side faces to the opening, the positive side faces to the liquid source, if driving circuit uses NPN transistor.