

Pro-Wave is a well-known manufacturer of various sensors and transducers and the basic sensing materials of piezoelectric ceramic and piezoelectric polymer films.

Our **GBD** series glass break detectors utilize the advance sensing technology of acoustic emission which only be responded in the frequency containing in the frequency over 200Khz of overtone frequencies containing in the frequency spectrum while glass being broken. It is unlike the microphone type detectors that can be easily activated by audible sounds and vibrations.

Up to 20 GBD series detectors can be wired in series and linked with all type security systems.



### Features

- Reliable ultrasonic emission sensing
- Latching LED indication
- Momentary opening contact
- Anti-tamper look wires
- Up to 20 detectors wired in series
- High impact resin enclosure

### Dimension

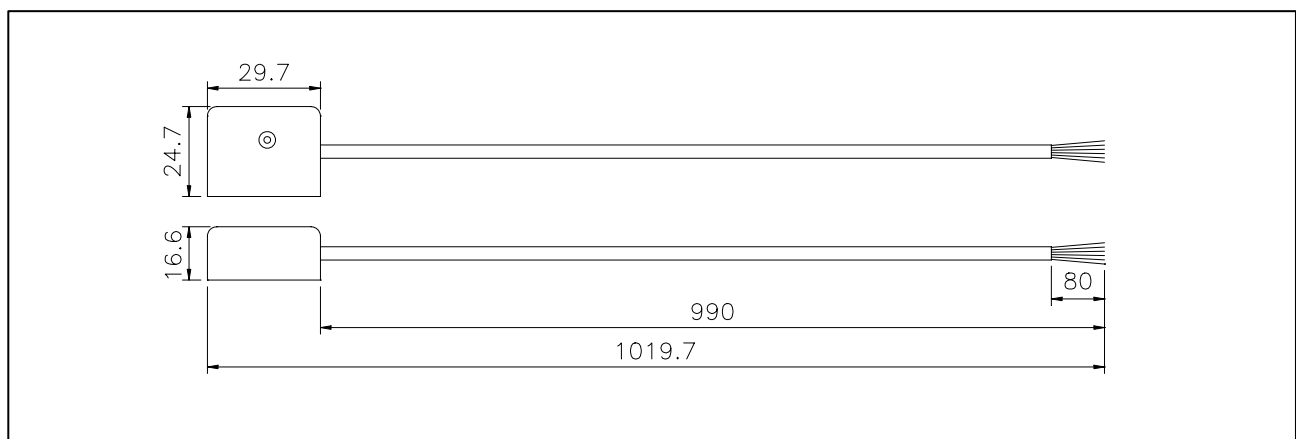

**S. Square Enterprise Company Limited**  
**Pro-Wave Electronics Corporation**

P.O. Box 1-70 Chung Ho, Taiwan, ROC; E-mail: [sales@pro-wave.com.tw](mailto:sales@pro-wave.com.tw); Tel: 886-2-22465101(5 lines), 22459774; Fax: 886-2-22465105

<http://www.s2.com.tw> ; <http://www.prowave.com.tw>

**Specification**

	GBD-02W	GBD-02B
Supply voltage	DC 11-15 volts	
Current consumption (standby)	2.5mA at DC 12 volts	
Contact rating	30 volts (maximum voltage) 0.5 Ampere (maximum current) 10VA (maximum power)	
Size	30.2 mm (length) x 25.3 mm (width) x 16.5 mm (height)	
Cable length	2 meters	
Color (ABS housing)	White	Brown

**Mounting**

After cleaning a suitable area of the windows (at least 5 cm away from any window frame with the cable going to the side or down) and **GBD** detector back with spirit cleaner (no nitro cleaner). The **GBD** detector is glued on the window with a temperature resistance glue, for example, RTV silicone rubber. The sensitivity depends on the glass thickness and reaches a maximum of 1.5 meter.

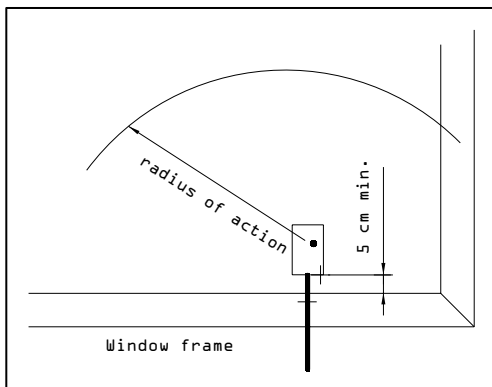

Glass thickness	Radius of action
8 mm	1.5 m
6 mm	1.5 m
4 mm	1.2 m
2 mm	0.6 m

**Connection**

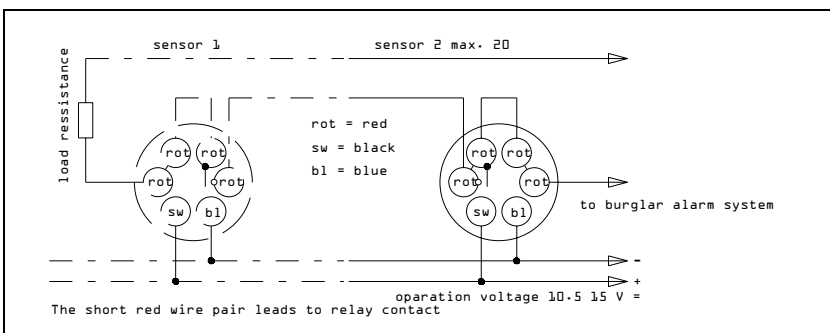

One or up to 20 **GBD** detectors can be wired in series according to the connection diagram including a termination resistor (4.7 – 22K Ohm). The wires of red and white are the relay output wires, the wires of yellow and brown are anti-tamper loop

wires, the blue one is the power input wire of DC –12 volts, the black wire is the power input of DC +12 volts.